

Tilt-up and Pre-cast Construction Code of Practice 2003

Workplace Health and Safety Queensland

Department of Justice and Attorney-General

Tilt-up and Pre-cast Construction Code of Practice 2003

Important information about the code

- The code was made on 12 May 2003.
- The code commenced on 1 June 2003.
- The code was amended on 28 April 2006 and 5 December 2008.
- The code expires 10 years after it commenced.

What is this code of practice about?

The purpose of the *Tilt-up and Pre-cast Construction Code of Practice* is to give practical advice about ways to manage exposure to risks associated with the erection and installation of tilt-up and pre-cast concrete panels and elements on construction sites in Queensland.

Workplace Health and Safety obligations and the *Workplace Health and Safety Act 1995*

The *Workplace Health and Safety Act 1995* places obligations on certain persons to ensure workplace health and safety. Workplace health and safety is ensured when people are free from risk of death, injury or illness created by workplaces, relevant workplace areas, work activities or plant or substances used at a workplace. Ensuring workplace health and safety involves identifying and managing exposure to the risks at your workplace.

How can I meet my obligations?

Under the Act, there are three types of instruments made to help you meet your workplace health and safety obligations - regulations, ministerial notices and codes of practice.

If there is a regulation or ministerial notice about a risk, you **must** do what the regulation or notice says.

If there is a code of practice about a risk, you **must** either:

- do what the code says or
- do all of the following:
 - adopt and follow another way that gives the same level of protection against the risk
 - take reasonable precautions, and
 - exercise proper diligence.

If there is no regulation, ministerial notice or code of practice about a risk, you must choose an appropriate way and take reasonable precautions and exercise proper diligence to ensure you meet your obligation.

Note:

There may be additional risks at your workplace, which have not been specifically addressed in this code of practice. You are required under the Act to identify and assess these risks and ensure that control measures are implemented, monitored and reviewed to prevent or minimise exposure to these risks.

This code of practice should be read in conjunction with the *Workplace Health and Safety Act 1995*, the *Workplace Health and Safety Regulation 2008* and the relevant Australian Standards, all of which impose obligations on various people to ensure a workplace remains healthy and safe.

Contents

| | |
|---|----|
| 1. Scope..... | 1 |
| 2. Introduction..... | 1 |
| 3. Panel design | 1 |
| 3.1 Cast-in lifting and bracing inserts | 1 |
| 3.2 Concrete strength and curing time | 2 |
| 4. Drawings | 3 |
| 4.1 Panel drawings | 3 |
| 4.2 Panel erection drawings | 4 |
| 5. Braces..... | 4 |
| 6. Wind loading..... | 6 |
| 7. Deadman design..... | 8 |
| 8. Drill-in type anchors..... | 10 |
| 8.1 Drill-in type anchors for brace connections | 10 |
| 8.2 Anchor setting torque..... | 11 |
| 8.3 Drill-in type anchors for lifting | 11 |
| 9. Engineer and verification issues | 12 |
| 9.1 Engineer certification..... | 12 |
| 9.2 On-site verification..... | 13 |
| 9.3 Variations from the design..... | 14 |
| 10. Non-standard panels | 14 |
| 11. Delivery and storage of panels and elements..... | 15 |
| 11.1 Transport to site | 15 |
| 11.2 Unloading from the truck..... | 16 |
| 11.3 Slings the load | 16 |
| 11.4 Storage of panels..... | 17 |
| 12. Crane issues | 17 |
| 12.1 Lift plan..... | 18 |
| 12.2 Crane capacity..... | 18 |
| 12.3 'Pick and carry' cranes..... | 19 |
| 12.4 Slewing cranes on outriggers | 20 |
| 12.5 Ground slope and condition | 20 |
| 12.6 Safe support of cranes on outriggers..... | 21 |
| 12.7 Lifting gear..... | 22 |
| 13. Work systems..... | 22 |
| 13.1 Exclusion zones for tilt-up panel erection..... | 22 |
| 13.2 Lifting pre-cast elements over workers | 23 |
| 14. Panel lifting and erection | 25 |
| 14.1 General..... | 25 |
| 14.2 Lifting of tilt-up panels | 27 |
| 14.3 Rotation of pre-cast panels..... | 28 |
| 15. Operation of plant near braces and panels | 30 |
| 16. Working at height | 31 |
| 16.1 Elevating work platforms (EWPs)..... | 32 |
| 16.2 Scaffolding..... | 33 |
| 16.3 Ladders..... | 33 |
| 17. Proximity to overhead powerlines | 34 |
| 18. Licensing issues | 36 |

| | |
|---|----|
| Appendix A - Sample of engineer's certification letters | 37 |
| Appendix B - Panel checklist..... | 39 |
| Appendix C - Panel lifting and temporary bracing checklist..... | 40 |
| Appendix D - Qualification register for panel erection | 42 |

1. Scope

This code of practice applies to the principal safety issues associated with tilt-up and pre-cast construction. It includes basic guidance on casting of panels, panel lifting and rigging systems, propping and securing of panels and work at height associated with panels and other pre-cast concrete elements. It does not consider all issues in this type of construction but focuses on the primary safety issues. This code of practice does not discuss pre-tensioning and post-tensioning of concrete elements.

2. Introduction

This code of practice has been developed in consultation with the building and construction industry. Guidance provided in the Australian Standard *AS 3850 – Tilt-up Concrete Construction* has also been referred to.

For the purposes of this document the term “panel” will be considered to include any tilt-up or pre-cast concrete element, whether it be a wall panel or any other element, unless a specific distinction is made.

3. Panel design

Tilt-up and pre-cast panels must be designed for both erection loads and for loadings experienced when they make up part of the completed building or structure (i.e. ‘in-service loads’). The loads applied to the panel during lifting off the casting bed and while the panels are temporarily braced, are different from loads experienced as part of the final structure. The design engineer(s) must therefore design the panel for both types of loading.

Where a panel is particularly large or has cut-outs the use of ‘strongbacks’ may be specified by the engineer to prevent failure of the panel when it is being lifted. It is extremely important that strongbacks are bolted so that they are hard up against the panel, or they may not be able to adequately resist the bending moment applied to the panel and the panel will be damaged.

3.1 Cast-in lifting and bracing inserts

The following should apply to the design and installation of lifting and bracing inserts:

- a factor of safety of not less than 2.5 against failure
- compliance with the manufacturer’s specifications for minimum edge distances, depth, concrete strength and additional reinforcement
- installation of an adequate number of inserts, in the correct locations, to ensure the inserts are not overloaded and to ensure the panel is suspended as near to vertical as possible.

AS 3850 specifies a factor of safety of 2.5 to 1 on lifting inserts for the particular application that the anchors are used. For example, the factor of safety is to be applied to the following:

- type of loading the insert experiences, i.e. whether it is a tensile or shear load or a combination of the two
- strength of the surrounding concrete
- maximum load that may be experienced by the insert.

The maximum load experienced by the insert usually occurs when the panel is lifted from its horizontal position and the bond with the casting bed is broken. The proper application of a quality bond breaker will greatly reduce the bond strength that has to be overcome by the lifting force.

All inserts require a minimum distance from the edge of the panel to develop their maximum strength. Some inserts also require tying to reinforcement steel. The insert type and the other information mentioned above must be clearly specified on the panel drawings and certified by an engineer (or a certification letter with a list of drawings should be supplied).

3.2 Concrete strength and curing time

Tilt-up panels should only be lifted when the concrete has cured long enough for the panel to be safely lifted and the 2.5 factor of safety can be maintained on the lifting inserts. The **minimum** concrete strength at which this can be achieved, for most proprietary brand lifting inserts is 25 MPa. Some inserts may require a higher strength than 25 MPa. Tilt-up panels are usually cast in stacks so the panels cannot be lifted until the last panel to be cast, on top of the stack, has reached adequate strength.

As a general rule concrete will usually achieve its maximum strength, for practicable purposes, after a period of 28 days. However, even after this period concrete can still increase in strength to a small degree.

In some situations the panel erector may cast the last panels on the stack with higher strength concrete (e.g. 40 - 50 MPa, 28 day strength) so the top panels can be lifted after a shorter period of time while ensuring the panels do not fail as they are lifted.

Water is sometimes added to the concrete to make it easier to work. This will weaken the concrete and affect its potential to reach design strength grade. It is therefore very important to strictly control the amount of water added to the mix.

The panel erector should provide written documentation to verify the concrete has reached the minimum acceptable strength. There should be a sampling and concrete testing procedure in place to verify concrete meets its design specification. Guidance on sampling and testing systems for concrete is provided in *AS 1379 - Specification and supply of concrete*.

It should be noted that the compressive strength of laboratory cured test specimens may differ from the actual compressive strength achieved on site due to factors such as temperature and humidity on site, poor curing techniques and the addition of water to the mix. Some panel erectors may therefore choose to have test samples on site to give an indication of the variation between 'on site' tests and laboratory tests.

Much of the concrete supplied for casting concrete panels is designated as 'special class concrete'. However, irrespective of whether the concrete mix is a special or normal mix, a sampling and testing program should be implemented.

Documentation verifying the following should be available on site:

- concrete specification of concrete supplied on site for use in panels
- minimum final concrete strength (i.e. 28 day strength) of concrete delivered to site
- minimum concrete strength to be achieved prior to lifting of panels (information for the inserts should be available that specifies the minimum concrete strength required for using the insert)
- results of a sampling program that demonstrates the concrete is of an appropriate strength, and
- casting dates for each panel and earliest date when the panel can be lifted (each panel should be numbered and written records made).

4. Drawings

Detailed drawings should be provided that includes information on the following areas:

- design of the panel itself for the in-situ application as part of the final structure
- design of the panel for lifting and other installation loads
- design and location of footings and slab for the building or structure
- layout of the panels during construction of the building or structure with temporary bracing installed, and
- layout of the building or structure in its completed form with temporary bracing removed and permanent connections detailed.

The builder and/or panel erector will often determine how many groups of drawings are to be provided for the project. However, all of the information above should be clearly shown on the drawings and is to be checked by a suitably qualified engineer.

4.1 Panel drawings

Drawings for the panel design should include the following information:

- date and issue number of the drawing
- location, orientation and depth of lifting and other inserts
- project location
- surface finish
- panel number and panel mass
- dimensional tolerances

- panel dimensions and centre of mass
- type and brand of lifting inserts
 - type, size and location of steel or other reinforcement
 - required concrete cover for reinforcement steel
 - strongback details (where required)
 - strongback fixing inserts details
 - concrete strength required both for lifting and as part of structure, in accordance with *AS 3600 - Concrete structures*
 - additional instructions for lifting inserts - such as edge distance and proximity of reinforcement.

4.2 Panel erection drawings

Drawings for the erection of the panels should include details on how the panels are to be placed and secured into position. Information to be shown on these drawings include:

- date and issue number of the drawing
- project location
- position of brace connection points on the panel and the ground
- brace specifications and/or required capacities¹
- levelling pad details
- relative locations of panels
- details for brace footings including dimensions, location, anchor type, and concrete strength at time of erection, and
- details on knee and lateral bracing (if applicable).

5. Braces

The safe erection of concrete panels relies on the integrity of braces and their correct installation. The different types of bracing for wall panels are illustrated in Diagram 1.

¹ If only the required brace capacities are specified on the drawing the panel erector should be able to demonstrate the braces being used have adequate capacity for the brace extension being used (the brace manufacturer may supply this information but there should be engineering input into the brace design).

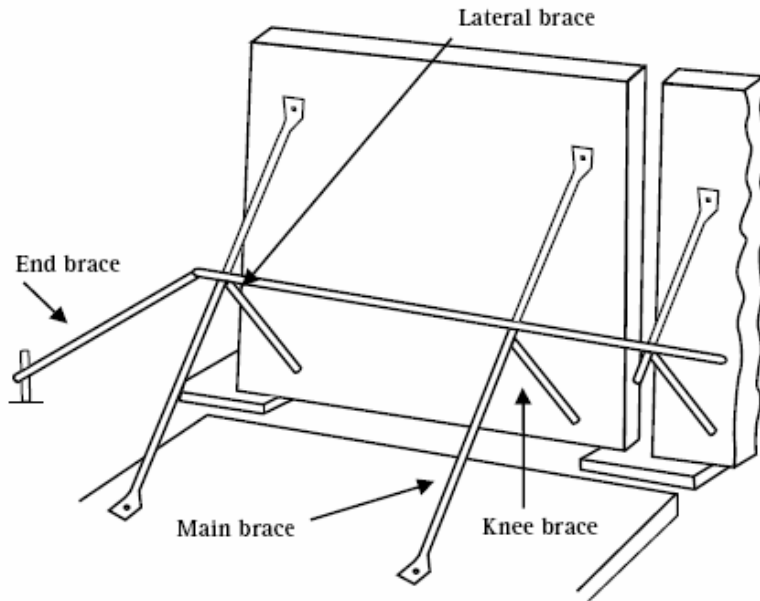

Diagram 1 – Bracing types

The following factors relating to the design and use of braces should be ensured:

- Braces should be permanently marked with the manufacturer's name or trademark, the model type and the working load limit for maximum and minimum extensions.
- Engineering computations or certification should be available and braces should be designed to have adequate strength and stiffness and allowance for wind loadings. Drawings and specifications which clearly show the type, position, method of fixing and installation angle should be on site.
- Braces should be designed to provide a factor of safety of two against failure.
- Braces should be as specified by the manufacturer and not have parts interchanged with other makes or models of brace (i.e. feet changed, smaller pins or bolts used, different tube wall thickness used).
- Prior to use all braces should be inspected to check there is no damage and to verify the braces are complete and functional (i.e. extendable and foot length can be adjusted).
- Bolts or nuts used to secure the brace to the footing or panel should be provided with washers of the correct grade and size.
- The anchor bolt and washer combination on the foot of the brace should have adequate bearing capacity. Sometimes the bolt head and washer are too small for the slot size on the brace foot. This can cause the washer to collapse and the panel to move. As a general principle the slot width on the brace foot should not exceed the diameter of the thread or sleeve on the anchor bolt by more than 2 mm - unless otherwise stated by the anchor supplier. In addition, the head of the anchor bolt should be large enough to be able to apply adequate load to the foot of the brace. If there is doubt about the ability of the bolt head to do this, the anchor supplier should be contacted and requested to supply guidance, such as the use of a suitable structural washer. Diagram 2 illustrates the issue.

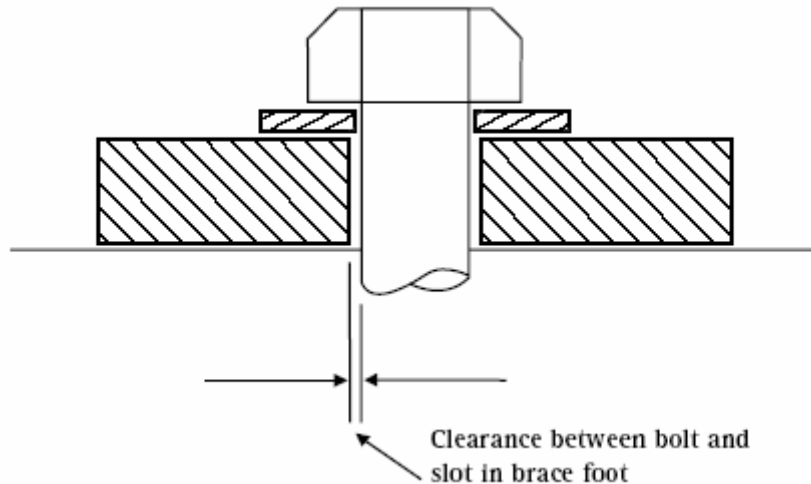

Diagram 2 – Adequate bearing capacity should be provided by the bolt head and washer

- Adjustable feet on braces should have stops on the threads to prevent over extension.
- Locking pins should be provided with retaining devices to prevent unintentional dislodgement of the locking pin. Consideration should be given to using retaining devices that require a tool to remove them to help prevent unauthorised persons tampering with the brace - this is of greater importance where such persons can gain access and/or where the locking pin can be reached by a person standing on the ground.
- A minimum of two braces should be secured to each panel unless specified by the engineer and indicated on the erection drawings. Where only one brace is used there should be a minimum of two fixings at each end (this may be difficult to achieve because of the lack of suitable feet and the need to maintain adequate separation distances for anchors), and
- Where knee bracing and/or lateral bracing is required by the engineer, it should be installed as soon as possible after the panels have been placed in position and the primary braces secured.

6. Wind loading

Wind loading on panels will vary depending on the size of panel, wind speed and wind direction. The location shall also have a bearing on the severity of the wind. In built up or hilly areas the wind effect may be less than on open plains. The area in Queensland will also have an effect - in cyclone prone areas the potential wind loading applied to panels will be higher.

Basic wind speeds for different zones in Australia are specified in *AS 1170.2 Structural design actions - Wind actions*. Diagram 3 shows the zones for Queensland. Three regions apply to Queensland as follows:

- Region A (normal) – covers most of the State but no coastal areas (includes Toowoomba, Mt Isa).

- Region B (intermediate) – includes coastal areas south of Bundaberg and a narrow band behind region C (includes Brisbane, all of Gold Coast and Sunshine Coast).
- Region C (tropical cyclones) – includes all coastal areas north of, and including, Bundaberg.

In addition to the area in Queensland, AS 1170.2 also specifies four different terrain categories that should be taken into consideration by the engineer.

For the purposes of designing restraint for tilt-up panels, categories 2 or 3 will often be used by the engineer. Category 2 applies to open terrain with few nearby obstructions, while Category 3 is applied when there are numerous obstructions between three and five metres high. The effect of the wind is more severe in wind Category 2 areas, which as an example might be near an airport.

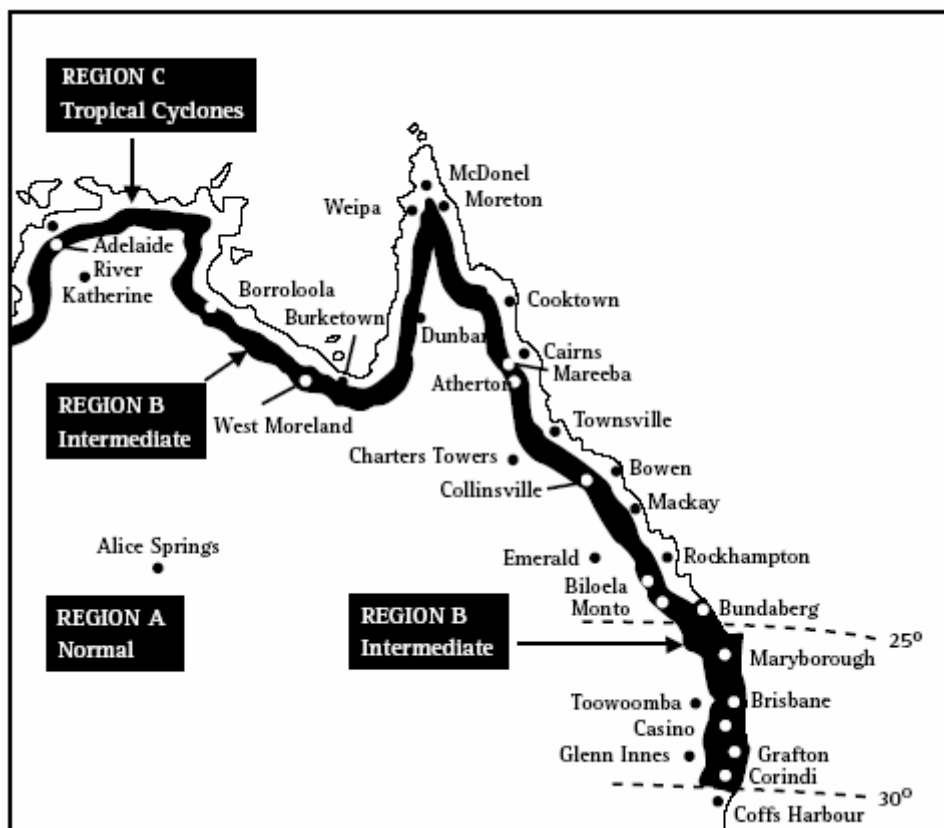

Diagram 3 – Basic wind speed zones for Queensland

There are a number of other factors that need to be applied by the engineer when calculating wind pressure on a panel and the resultant number of braces and size of deadmen required. However, it should be noted that the number of braces required is not directly proportionate to the basic wind speed. The dynamic wind pressure (q_z) is calculated using the following equation:

$$q_z = 0.6V_z^2 \times 10^{-3}$$

(V_z is wind speed in metres per second and q_z is in kilopascals).

It can be seen from this equation that the wind pressure will vary directly to the square of the wind speed. Therefore a small increase in the wind speed will result in a much larger increase in the pressure and a much larger increase in the number of braces required or size of deadman required.

With the above in mind the number of braces required for a tilt-up panel in a coastal tropical area will often be greater than that required close to Brisbane.

7. Deadman design

Buried concrete blocks ‘deadmen’ are commonly used to anchor braces and prevent panels falling over due to wind loads or other factors. An example of a deadman is shown in Diagram 4.

A deadman relies both on its mass and cohesion with the ground to resist wind loads tending to pull the deadman out of the ground (i.e. wind blowing on to the back face of the panel). Wind blowing onto the front face of the panel will result in a compressive force in the brace which will tend to push the deadman further into the ground. Of the two different loading cases the case where the wind tends to pull the deadman out of the ground is the more critical. It should also be noted that with this load situation there is a horizontal component of the force that will tend to pull the deadman through the ground, but this will usually not be the critical factor in the design of the deadman.

Soil that is stiffer will provide greater degrees of cohesion, and will be better to resist pull out loads, than sandy soils. Therefore stiff clay will have better cohesive properties than gravel. Sand will provide very little cohesion and the size of the deadman will therefore need to be larger.

Because the adequacy of the deadman to resist wind loads is based on both its mass and cohesion with the ground, the mass of the deadman is not directly proportionate to the surface area of a panel. The cohesion is based on the surface area of the block in contact with the soil and the effect of this will vary at a different rate to a variation caused by the mass of the block (e.g. when the mass of a cubic block is doubled its vertical surface area will not be doubled). It is therefore not a simple process to estimate the size of a deadman block for a particular panel based on the calculated size of a block for a smaller panel. It should also be noted that the effectiveness of the cohesion of the block with the ground will depend on an effective contact between the two solids. For instance, in clay there will not be effective cohesion where the ground has been disturbed at the top of the hole.

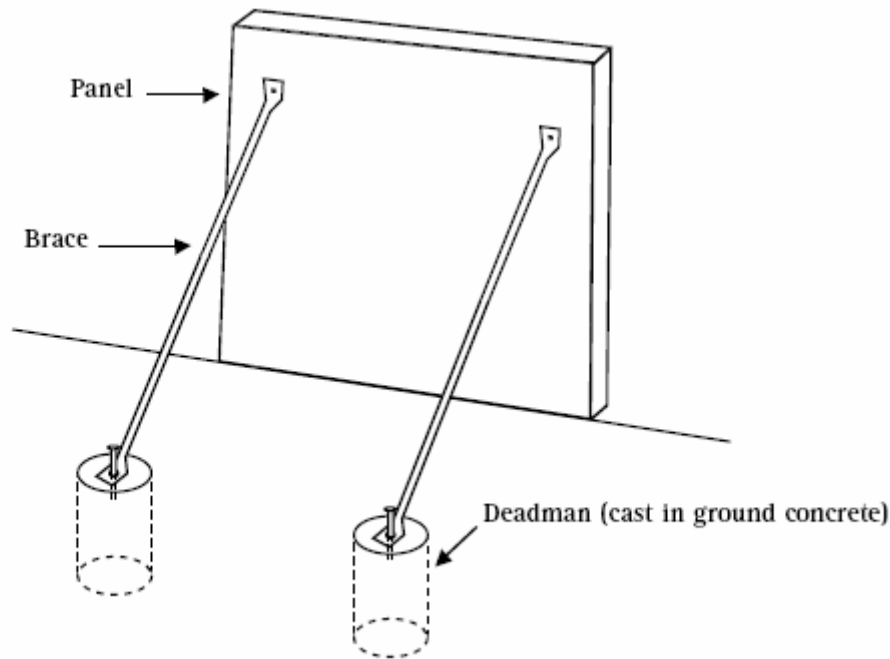

Diagram 4 – Deadman for anchoring braces

A deadman is usually provided with a cast-in reinforcement bar to connect the brace foot to the concrete block. The bar will often be bent at right angles in the deadman and this greatly assists the strength of the bond between the steel and concrete. Sometimes the steel bar is not bent but is simply a straight bar that is pushed into the wet concrete. In this situation it is critical to ensure the engineer has checked the design of the steel insert and the correct section of steel is inserted to the minimum required depth during construction of the deadman. If the steel is not inserted correctly it can either pull out of the deadman or cause cone failure of the concrete when loads are applied.

Deadmen are typically cast using low strength concrete (e.g. 20 - 25 MPa) and there will usually be a need to leave them for a substantial amount of time to ensure the cast-in or drill-in type anchors do not pull out.

The following information should be available on site:

- drawings that show deadman dimensions, concrete strength, steel content and location (if applicable), terrain category (for wind), and soil type
- documentation that verifies each of the deadmen have been constructed in accordance with the drawings and the concrete has obtained its minimum required strength prior to installation of the braces and/or installation of drill-in type anchors
- documentation that verifies anchors comply with the minimum edge distances specified by the engineer or the anchor manufacturer, and
- verification that the deadmen are able to resist wind loadings on the panels in accordance with *AS 1170*.

The verification should either be in the form of an engineer's written certification for that particular site or in the form of test results. The engineer's written certification

should state that the deadmen can adequately withstand wind loadings specified in *AS 1170*. Where the verification is in the form of test results there must be correlation between the test results and the actual conditions on site. The test should be performed by an independent competent person. Where test results are used as verification, evidence of the following should be provided:

- the ground compressive strength on site to be at least equal to the conditions where the test was carried out (ground type and water content have a large effect on ground strength)
- the dimensions of the deadmen to be the same or greater than those of the test deadman, and
- the resisting force of the deadmen to be greater than the maximum load applied by the panel to the brace and to incorporate a suitable factor of safety (specified by the engineer). The load applied to the brace is to be specified by an engineer and should be calculated in accordance with *AS 1170*.

In some situations panels may be erected in locations where solid rock exists. In such locations alternative methods of anchoring the braces to the ground may be used, but these should be specified and certified by an engineer.

8. Drill-in type anchors

8.1 Drill-in type anchors for brace connections

The use of cast-in inserts is preferable to the use of 'drill-in' type anchors to fix tilt-up braces. Most anchors require a minimum concrete strength of between 20 and 25 MPa to achieve their specified capacities. Where drill-in type anchors are used these may be of the following type:

- Undercut type anchor that does not rely on friction to function.
- Expansion anchors of the high-load slip, torque controlled type. These anchors have a working load of at least 60 percent of the first slip load and are generally suitable for structural tensile loads, or
- Coil bolts - it should be noted that the correct operation of these bolts is very dependent on their correct installation in accordance with the manufacturer's specifications (e.g. drilling the correct size hole and applying the correct torque in concrete of adequate strength).

In relation to expansion anchors and coil bolts it should be noted that the permissible load on the anchor should not exceed 0.65 of the first slip load. If the capacity of the anchor is quoted as the first slip load, this figure will need to be multiplied by 0.65 (reduced by 35 percent) to find its permissible load. The first slip load is the load applied that will cause the anchor to move 0.1 mm when the anchor is installed in accordance with the manufacturer's specifications.

Data supplied by the anchor manufacturer on the first slip load and the maximum working loads should be available on site.

It should also be noted that the capacity of the anchor is restricted by the slot size (fixing hole) on the foot of the brace. The slot on most brace feet is not wide enough for anchors in excess of 20-22 mm outside sleeve diameter. This will often mean that the largest expansion anchor that can be used will incorporate an M12 size bolt. The permissible tensile load on a high-load slip, torque controlled anchor incorporating an M12 bolt will generally not exceed about 12 - 14 kN. This capacity may be less than the capacity of the brace, which may be in excess of 20 kN. In some instances the anchor will therefore limit the permissible capacity of the brace. In such instances the engineer will either have to:

- specify the use of an anchor with higher capacity (such as an undercut anchor)
- increase the number of braces used on the panel, or
- specify the use of more than one expansion anchor on the brace foot and specify a foot that is both large enough and has the ability to have two anchors attached.

The following types of drill-in type anchors **should not be used** for anchoring braces:

- deformation controlled expansion anchors
- drop-in type anchors
- low-load slip deformation controlled anchors. These anchors may sometimes be known as wedge anchors, usually have thin shields, and do not reliably retain more than 20 - 40 percent of the initial pre-load, and
- self-drilling anchors.

Chemical anchors should not be used unless each fixing is individually proof tested to the working load limit and documentation verifying this is available on site.

8.2 Anchor setting torque

Verification of setting torque for all drill-in type anchors should be documented and available on site. Torque controlled type anchors depend on correct torque setting to operate correctly. Manufacturers of these anchors will not guarantee the anchors if the setting torque is incorrect. Under-torquing the anchors will mean their maximum pull out strength cannot be achieved and over-torquing the anchors may damage them (i.e. strip the thread).

The setting torque of the high-load slip, torque controlled type anchors using M12 bolts typically ranges between 60 and 80 Newton-metres (Nm). The setting torque of 19 mm coil bolts typically ranges between 220 and 360 Nm. The torque for coil bolts is very high and it is extremely difficult for a worker to apply such torque with a shifting spanner (i.e. a bigger lever arm is usually required).

Drill-in type anchors should have their torque set using an appropriate torque wrench or another reliable method that will verify the torque (i.e. a calibrated 'rattle gun'). Written records verifying the setting torque for all drill-in type anchors should be available on site.

8.3 Drill-in type anchors for lifting

In some situations it may be intended to use drill-in type anchors for lifting panels - this may be the case where the cast-in insert is defective or placed in the wrong position, or where older panels are being lifted. Lifting with drill-in type anchors is not the preferable method of lifting panels due to the following reasons:

- difficulty experienced in drilling holes of the correct depth and location due to the presence of steel in the panel
- potential problems in ensuring the correct setting torque is applied, and
- the reliance on friction or bonding strength to maintain the anchors' integrity.

Where drill-in type anchors are used for lifting panels, in tension or partial tension, every anchor should be proof loaded. The proof loading should be a direct 'pull out' load and be equivalent to the load to be experienced when lifting takes place (a factor of safety of at least 2.5 should apply to the anchor). Records of the proof testing should be documented.

9. Engineer and verification issues

9.1 Engineer certification

Persons providing design certification should be Professional Engineers with suitable experience.

Engineers should provide specific signed statements about the compliance of the system with AS 3850.

The following documentation and certification should be provided on site:

- Certification for the panel design for in-situ loading, wind loads and erection loads - (i.e. loads applied when panel is lifted off the casting bed).
- Specifications for the concrete footings used to support concrete panels in their final position (e.g. footings for the walls). The principal contractor will supply this information.
- Drawings for the panel design, temporary bracing layout, final building layout and footing details (see section 4 'Drawings'). The drawings should be signed by an engineer or be accompanied by a certification letter that lists the panel drawings and drawing revision numbers.
- Design certification for the temporary support system. This should include certification for:
 - brace specification including capacity, type, extension, installation angle
 - anchor bolt specification, type, and capacity, and
 - deadman block or footing/slab design including steel content, concrete strength and minimum edge distances for cast-in inserts or drilled-in type anchors.
- Any other instructions that may be required to ensure the safe erection and securing of the panels - i.e. the engineer may need to endorse the procedure for brace removal and connecting the panels to the building's structural steel, particularly if the steel structure is not complete prior to removal of the braces.

Two examples of engineers' certification statements are included in Appendix A. One statement refers to the strength of a panel to resist lifting and in-situ loading while the other refers to the temporary bracing of panels and their ability to resist wind loading.

9.2 On-site verification

The total design of the panel erection system should be overseen by engineer(s). This includes design of the panels, temporary bracing systems and securing of panels prior to removal of braces. An appropriate system that verifies compliance with the design should be implemented. On-site audits will assist to verify factors such as the following:

- the correct grade of concrete is being used and panels are being left to cure for the appropriate amount of time prior to lifting
- use of the correct type and number of concrete inserts and installation in accordance with the manufacturer's specifications
- installation of reinforcement steel in accordance with the drawings - both in the panels and deadmen, and
- installation of panel braces in accordance with the engineer's and manufacturer's specifications.

Persons on-site may be delegated to verify and document that the design has been complied with. This decision is sometimes made for cases where the construction process is of a repetitive nature.

Should the person on-site not be an engineer, this person should only verify that the engineer's specifications and drawings have been complied with. This person should not authorise variations to the design unless he or she is a suitably qualified and experienced engineer. However, it should be noted that the person verifying compliance with the engineer's specifications would need to be experienced in tilt-up construction and be competent in reading drawings.

Two checklists that may be used for on-site verification are included in Appendix B and C. The "Panel checklist" relates to the structural integrity of the concrete panels themselves both for in-situ and lifting loads during erection. This checklist may be used for either pre-cast or tilt-up panels and should be completed prior to panels being lifted. In the case of pre-cast panels, the completed checklist would usually be supplied when panels are delivered to the site. The "Panel lifting and temporary bracing checklist" applies both to the safety of the lifting system used by the panel erectors and to the integrity of the temporary bracing system. The first part of the checklist under the 'panel lifting' section should be completed before lifting takes place when the crane is on-site. The second part can be filled out as the panels are being erected and should be completed prior to the panel erector leaving the site on that particular day.

It is considered that the appropriate design engineer should at least carry out some on-site audits, to assist compliance with the design specifications and to help the engineer become familiar with difficulties experienced on site. It may be advisable for the engineer to visit the site during the following phases of construction:

- casting of the wall footings or other footings used to support tilt-up or pre-cast elements
- pouring of the deadman or footing/slab design to which panel braces will be attached
- pouring of tilt-up or pre-cast panels
- temporary bracing of panels on site, and
- just prior to the removal of temporary braces from the panels (after panels have been attached to the building's internal structure).

Prior to removal of temporary bracing from the panels an inspection of the building should be made by a competent person to ensure that all permanent structural members and brackets have been attached to the panels in accordance with the engineer's instructions. A sign off procedure should be implemented to verify that this has been done and temporary braces can be removed.

9.3 Variations from the design

All variations from the design, relating both to the panel and support system, should be checked by the engineer and either be:

- certified by the engineer as being acceptable (i.e. complying with *AS 3850*) in writing, if the engineer can verify this is the case, or
- altered in accordance with the engineer's written directions so as to comply with *AS 3850*, within a time frame specified by the engineer.

Some of the variations that may apply include:

- Two braces anchored to one deadman when the engineer's original specifications state that each brace is to have a separate deadman (note: this cannot be done unless the deadman is substantially larger because of the minimum separation and edge distances required between cast-in or drill-in type anchors).
- The brace angle in the vertical plane is not within the range specified in the erection drawings.
- The brace angle in the horizontal plane exceeds 5 degrees from the perpendicular.
- The absence of knee and/or lateral bracing when this had been specified originally by the engineer.
- Only one brace is provided on narrow panels, when *AS 3850* states there should be a minimum of two (note: *AS 3850* permits the use of one brace if the engineer specifies this to be the case. However, the standard also states that two anchors are to be provided on each end of the brace. This cannot be done on brace feet that only have provision for using one anchor, and
- Removal of braces from panels prior to all permanent structural members being attached to the panels.

10. Non-standard panels

The erection of non-standard panels may require the use of specialised lifting and bracing techniques. This may be the case when there are special architectural features on the building or cut-outs in the panel. Specific instructions highlighting special

erection and support procedures to be followed should be endorsed by the engineer and available on site. Two examples of where specific procedures may need to be followed are as follows:

- A panel in the shape of an inverted 'L' is to be lifted and placed in position. The panel may require strongbacks to ensure it does not fail when lifted (see Diagram 5). The position of the lifting inserts and rigging set-up will need to be specified so that the panel hangs vertically and not on an angle (i.e. with bottom edge horizontal). To ensure the panel will not fall over it may need to be suitably propped under its unsupported side, and
- A panel has braces attached so that one or more braces has to be removed prior to the panel being attached to structural steelwork. A work system will have to be used that will ensure the panel does not become unstable when the braces are removed.

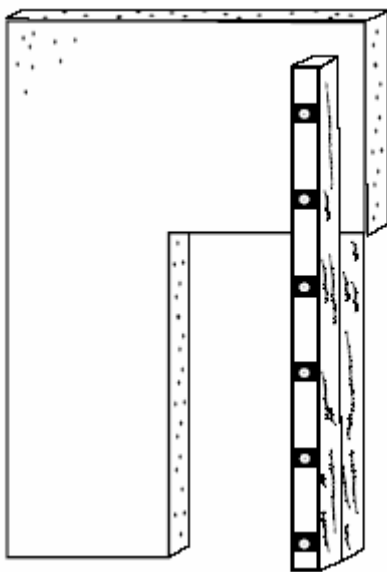

Diagram 5. Unstable panel requiring method of support

11. Delivery and storage of panels and elements

11.1 Transport to site

Pre-cast concrete panels and elements should be transported to site in a safe manner and loaded on trucks so that the panels will not fall off the semi-trailer, make the vehicle difficult to drive or make the panels difficult to unload. Panels should be restrained on the trailer by a system that ensures the load is evenly distributed and withstands movement of the panels during transport. Panels should also be loaded and secured such that they will not become unstable when the restraint system is released on site (i.e. on an A-frame the panels lean inwards against the frame when the chains are undone).

Guidance on suitable methods of restraining loads on road transport vehicles is provided in the following guides:

- *“Load Restraint Guide - Guidelines for the Safe Carriage of Loads on Road Vehicles”, produced by the National Road Transport Commission.*
- *“Load Restraint Guide, section D: A Guide to Restraining Concrete panels”, published by VicRoads.*

The truck driver should be adequately trained and experienced in the transport of concrete elements. Permits for over-sized loads should be obtained prior to the semi-trailer travelling to site. When selecting the route from the pre-cast yard to the construction site the following issues should be considered:

- low bridges
- height of power and other lines
- train lines, and
- roundabouts and reverse camber corners.

11.2 Unloading from the truck

When unloading panels the semi-trailer should be located on firm, level ground. The side slope should be minimal and not exceed 2 degrees (2 degrees is usually just discernable to the human eye). It is advisable to chock the wheels of the vehicle, in addition to applying the park brake. The trailer should be unloaded in a progressive manner that ensures any tilt of the trailer is kept to a minimum. For example, on an A-frame where there is more than one panel on each side, one panel should be removed from one side then one removed from the other side. If panels are removed so that the trailer tilts, other panels on the trailer may fall off. It may be necessary to lower the front support legs of the semi-trailer prior to removing the panels - this will help to reduce movement of the trailer.

The semi-trailer should never be moved after the restraint system is released.

During unloading, only persons involved in the unloading should be in the area around the vehicle, and others should be excluded. No persons should stand beside the vehicle in an area where they would be struck by a panel if the vehicle were to be knocked or move.

11.3 Slinging the load

Pre-cast panels will normally be provided with lifting inserts on the top edge of the panel delivered to the site. This could mean that the dogger slinging the load is required to work more than 2 metres above the ground. The use of ladders to sling the load could be unacceptable because the dogger needs both hands free to sling the load and because it is difficult to secure the ladder. The provision of a work platform for the dogger to work from should therefore be provided. Some of the alternatives for providing safe access for the dogger are as follows:

- a walkway along the length of the A-frame that prevents a fall occurring (i.e. the dogger has a barrier at least 900 mm high on both sides of the A-frame) - in this instance access could be provided to the walkway by a secured ladder at the rear of the trailer)

- pre-attached slings on the panels that can be reached by the dogger while standing on the ground (these would have to be set up so that they could not snag on any obstructions)
- a boom type elevating work platform where the basket can be moved close to the sling connection points on the panel
- a mobile scaffolding provided with edge protection and safe access
- a loading bay beside the semi-trailer.

11.4 Storage of panels

Where concrete panels and elements are not lifted directly into position, they should be stored so that they are stable even in windy conditions. The following factors should be considered when storing concrete elements:

- An engineer may need to provide guidance on storing panels as the loadings applied to the panel when moving it into the storage position may be very different than those applied as part of a wall.
- Where laid out flat, concrete elements should not be stored directly on the ground as this can damage the element or make it very difficult to lift. A minimum of two support points, such as timber bearers, should be provided under the panel (more supports may be required for larger panels to prevent the panel cracking).
- When panels are stacked horizontally on top of each other the support points should be directly above each other unless otherwise specified by the engineer.
- The stacked height of elements should be limited to ensure the ground bearers and lowest elements can support the load.
- The stack height should not be higher than twice the element width unless specifically documented by a competent person.
- Where an element is stored on a suspended floor slab, this should be approved in writing by the design engineer of the suspended slab, and
- Panels should be stored in a location where it is unlikely they will be struck by vehicles - i.e. not next to roads.

12. Crane issues

The information relating to cranes in this document relates specifically to the use of cranes for tilt-up and precast panel erection.

The selection of an appropriate crane, preparation of the site and correct location of the crane are crucial in ensuring the safe erection of concrete panels. Mobile cranes used for this type of construction are usually required to work close to their maximum capacity and with high luff angles and boom length due to the large size and mass of concrete panels. These factors increase the likelihood of the crane overturning, particularly if the ground is not level.

12.1 Lift plan

A lift plan should be prepared prior to lifting tilt-up or pre-cast panels. The plan should show a dimensioned site plan with the following information detailed:

- crane set-up position(s) on site
- locations where the panels are to be lifted from and to, with the operating radius of the crane shown
- areas on site where obstacles such as walls or braces may be in the travelling or slew path of the crane, and
- areas where the crane cannot be set up (i.e. trenches and covered penetrations on site).

The lift plan should specify the type and set up of lifting gear to be used.

Responsibilities for rigging, dogging and spotting duties (i.e. ensuring the crane does not contact obstacles) should be specified.

12.2 Crane capacity

The crane capacity must be adequate for the largest panel mass, radius and boom length that is used. It should be remembered that a mobile or tower crane's maximum rated capacity rarely gives a practical indication of the load the crane can actually lift as this capacity is taken at a distance very close to the slew centre of the crane.

When lifting a panel using face lifters the panel's centre of gravity will be at a greater radius than the bottom edge of the panel. The crane being used should therefore have adequate capacity to safely suspend the panel at the greater radius. Diagram 6 illustrates the point. As a general guide, at least 1.5 metres should be added to the working radius of the crane. This may need to be increased for very tall panels.

As a general guide, mobile cranes used on tilt-up construction usually have a maximum rated capacity of at least three times the mass of the heaviest panel to be lifted. As an example, with a tilt-up panel of 20 tonnes mass a mobile crawler crane with a maximum rated capacity of 60 tonnes will generally have adequate capacity. It should be remembered that this is a guide only. In some situations it may be acceptable to use a smaller crane and in some cases a larger crane may be required. For instance, a much larger crane may be required where the crane cannot be positioned close to the casting bed or final position of the panels. The crane operator should be able to show the load being lifted is within the capacity specified in the load chart. The load to be lifted includes the panel weight, lifting gear weight and dynamic factors. When a mobile crane is used the hook block weight should also be added - unless the load chart specifies otherwise.

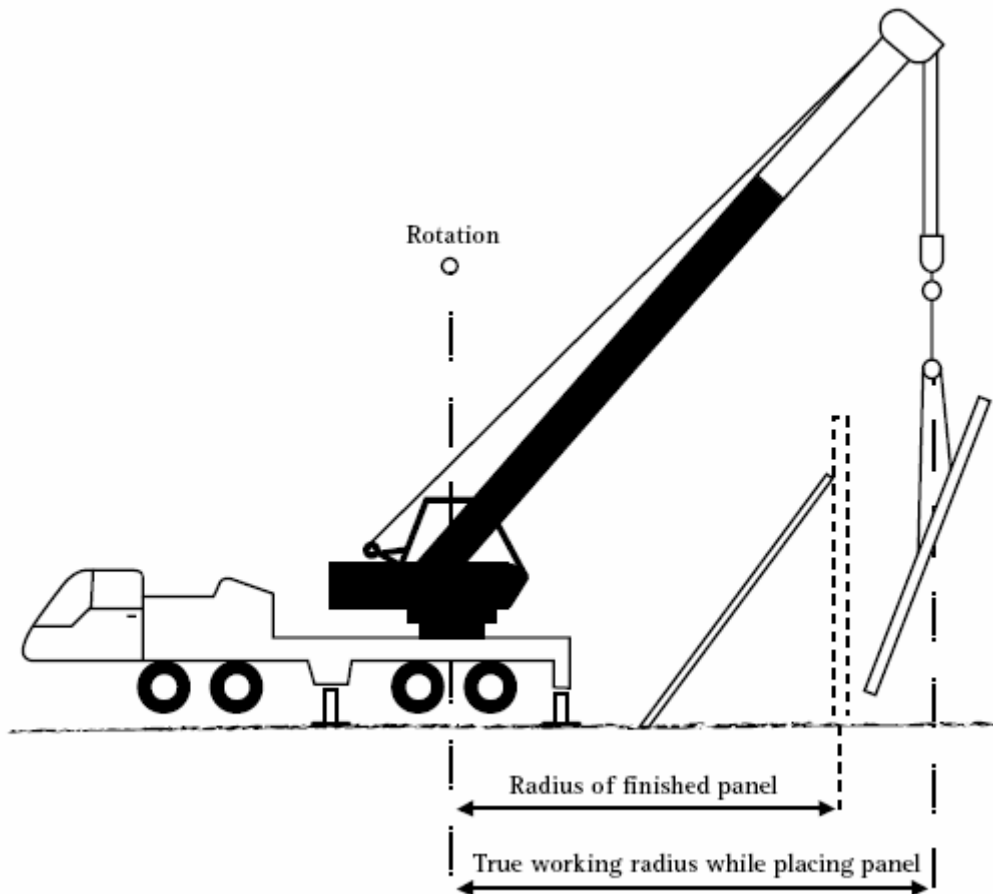

Diagram 6 – Increased crane operating radius for lifting tilt-up panels

Note: The true working radius from the centre of rotation to the hook will depend on actual details

12.3 'Pick and carry' cranes

There are basically three types of pick and carry mobile cranes – lattice boom crawler cranes, articulated non-slewing cranes and rough terrain hydraulic slewing. Rough terrain cranes can also be used on outriggers but are not used very often on tilt-up construction.

Lattice boom crawler cranes are used on the majority of tilt-up jobs due to their large lifting capacity and good stability characteristics.

Articulated non-slewing cranes are also used on some smaller panel jobs. The use of these cranes in tilt-up construction has increased since the introduction of larger capacity cranes.

Although the use of rubber tyred articulated cranes may be acceptable for lifting panels in some situations, these cranes are generally not suited for reasons including the following:

- The lifting capacity is generally too low for most panel jobs (the largest crane of this type has a maximum capacity of 25 tonnes and will usually only be suitable for lifting smaller panels of say 8 tonnes or less).
- These cranes are more prone to overturning than are crawler cranes due to:
 - being articulated
 - supported by rubber tyres that compress
 - having wheels that are more prone to enter ground depressions than are tracks
 - having hydraulic booms that are heavier than lattice booms.

The load chart for pick and carry mode should be based on 66.6 percent of tipping where travel speed is greater than 0.4 m/s (1.44 km/h). A load chart based on 75 percent of tipping is acceptable where the travel speed is less than 0.4 m/s (for further information refer to section 9, *AS 1418.5 – Cranes, hoists and winches – Mobile cranes*).

12.4 Slewing cranes on outriggers

Slewing cranes set up on outriggers are being used to an increasing extent for tilt-up construction due to the availability of larger capacity cranes and ‘all terrain’ type cranes that can more readily gain access onto site. Cranes of this type being used for panel work usually have hydraulic booms although there are still some older lattice boom models being used. The drawback with using this type of crane is that they must remain in one position while performing a lift, unlike a pick and carry crane. A crane on outriggers therefore has to be located so that the casting bed and final position of the panel are within the safe operating radius of the crane for the particular panel being lifted.

When using mobile cranes on outriggers for tilt-up construction, it is particularly important to ensure the crane is set up in the best location where the potential risk of the crane causing damage to the structure is minimised. The crane should be positioned so that the counterweight cannot contact any obstructions, including panels and panel braces, when the crane slews. If this cannot be achieved, suitable control measures should be implemented to prevent the counterweight contacting obstructions (see section 15 “Operation of plant near braces and panels”).

The use of a larger capacity crane will reduce the necessity for repositioning the crane between lifts. However, it should be noted that using larger cranes may increase the likelihood of the counterweight contacting braces and panels. A larger crane will also be more difficult to safely manoeuvre around site.

12.5 Ground slope and condition

The ground condition and slope are critical factors that will affect crane stability particularly when the boom is at its full length and maximum luff angle (minimum operating radius). This situation is often the case with tilt-up construction.

Where the ground slope is greater than 1 degree, written evidence that the crane can safely ‘walk’ a load for the particular gradient should be provided. The crane

manufacturer or a competent person such as an engineer with relevant experience may be able to provide guidance on this.

Mobile plant operators are not qualified to calculate how much to de-rate the capacity of a crane or how much a boom is to be lowered, when traversing sloping ground.

A minimal ground slope can be a major factor in causing the crane to overturn. A side slope of only 2 or 3 degrees can have a drastic affect on the stability of the crane when walking panels. As an example, tests carried out by one manufacturer for a particular model of pick and carry crane indicated the crane's capacity should be **de-rated by more than 70 percent** when operating on a side angle of 5 degrees (with maximum boom extension, luff angle and steering articulation). Soft ground, pneumatic tyres, ground depressions and spring movement (where lockouts are not fitted) will also tend to increase the side angle of the crane and make the risk of overturning greater.



Diagram 7 – Rubber tyred pick and carry crane overturned

Side gradients will generally be more critical than gradients in the direction of travel, but any gradient will have an effect on the maximum capacity of a crane.

Where there is doubt about the ground strength, it may be necessary to request verification on the ground's bearing capacity by a competent person (i.e. geotechnical or soil engineer) from the person in control of the site. This could be the case:

- where the ground has not been compacted
- in muddy or very wet conditions
- where the crane and or panels are particularly heavy (e.g. panels over 25 tonne)
- where the working radius of the crane is large
- where underground services or cavities are identified, or
- due to a combination of the above.

12.6 Safe support of cranes on outriggers

Where the crane is set up on outriggers the following should be ensured:

- Timbers are correctly pig stied under the outrigger pads. Timbers should be robust and be of a minimum size and strength specified by the crane manufacturer.

- The crane is not set up next to excavations or over ground cavities that are covered. Prior to setting up a crane on site, information on excavations and underground services should be provided by site management.
- The crane is set up so that it is level to within a tolerance of 1 degree or less - a level indicator ('bubble gauge' or electronic) should be provided to show the crane is level, and
- The area of the outrigger timbers or steel plate is adequate for the loadings and bearing capacity of the ground. Particular caution should be taken on soft ground and the minimum bearing area required for outrigger support should be calculated by the crane operator, where there is doubt about the ground strength.

12.7 Lifting gear

Guidance on the use and inspection of chains, wire ropes and synthetic slings is provided in Australian Standards² and in "A Guide for Doggers" (Workplace Health and Safety Queensland). The basic items that should be checked are as follows:

- the lifting gear is tagged and all relevant information listed (such as in the case of a chain sling – grade of chain, safe working load, manufacturer, chain size)
- lifting hooks are provided with operable safety latches
- shackles are prevented from unscrewing
- lifting eyes and inserts are compatible and the same proprietary brand
- lifting slings are not damaged (for example: excessive wear, damaged strands, cracks, deformation, severe corrosion)
- the sling is appropriate for loads being lifted - including adequate capacity and protection from sharp edges.

13. Work systems

13.1 Exclusion zones for tilt-up panel erection

Only persons directly involved with the erection of panels should be located in the area while lifting is taking place and such persons should avoid being in a position where they could be struck in the event of a crane or panel falling over.

In any type of lifting activity the crane operator should avoid lifting the load over persons. However, with tilt-up construction the risk to persons is greater for the following reasons:

- Panels can be very susceptible to wind loads because of their shape and size.
- If a panel falls over or an insert fails, while the panel is attached to the crane, it is very likely that the crane will overturn. Other panels may also be struck and fall

² AS 2759 – *Steel wire rope – Use, operation and maintenance*
 AS 3775 – *Chain slings – Grade T*
 AS 4497.2 – *Roundslings – Synthetic fibre – Care and use*
 AS 1353.2 – *Flat synthetic-webbing slings – Care and use*

over. The potential consequences of an incident are therefore usually more serious than when other items are lifted.

- There is usually greater risk when lifting a concrete element (i.e. than a steel object) because the integrity of the load relies on a number of factors such as concrete strength, steel content and position, lifting insert integrity and correct operation of the lifting clutch. Due to the greater number of variables there is a greater risk of an error being made, and
- It is generally impractical to provide an effective secondary back-up lifting system for a tilt-up panel (i.e. it is too difficult to place a lifting sling around the panel because the panel is cast on the ground).

In view of the above, all persons not involved in the erection of the panels should be prevented from accessing the erection zone. Workers should not be located where they could be struck by the panel in the event of lifting gear failure or strong winds. An exclusion zone should be set up that prevents unauthorised persons gaining access. On some jobs this may necessitate the erection of para-webbing, signage and/or fencing depending on the ease of access and the likely presence of persons, either workers or members of the public. The exclusion zone should be set up so that it includes an area where persons cannot be struck either by:

- the crane falling over
- the panel being lifted falling over, or
- another structural element failing and falling to the ground as a result of being struck by the crane or the panel being lifted.

The exclusion zone should be maintained during panel lifting until braces have been secured and the lifting slings removed.

Where a road or other vehicular access way is located in the exclusion zone, traffic should be prevented from passing through the zone while panels are being lifted and prior to securing of the panels with braces.

Adjacent buildings that may collapse in the event of a panel falling should have persons removed from risk areas. If this cannot be ensured, panel lifting on that part of the job should be performed out of hours when persons are not located in the building.

13.2 Lifting pre-cast elements over workers

Similar hazards apply to the erection of pre-cast elements as tilt-up panels. The same principles therefore apply to the setting up of exclusion zones both for members of the public and workers. However, it is acknowledged that in some situations it can be extremely difficult to set up exclusion zones for workers during the erection and installation of precast elements. This may be the case for installation of pre-cast wall panels on high-rise projects or where pre-cast floor planks are installed on large projects with multiple crane operation (i.e. the cranes' operating radii overlap). With this in mind it is considered that the lifting of pre-cast elements over workers can be performed providing the following conditions are followed:

- An effective back-up lifting system is provided for the element in the event of failure of the primary lifting system.
- The back-up system is designed and certified by a suitably qualified engineer.
- The primary and back-up lifting systems are not removed until the concrete element is secured in place and is no longer suspended by the crane.
- Measures are implemented to ensure that any lifting over workers is kept to a minimum.
- The crane is inspected prior to lifting and all parts and safety features of the crane are operating in accordance with the manufacturer's specifications - this includes load indicators, overload cut-off systems and braking systems.
- Lifting gear, including spreaders, chain, wire ropes, hooks, lifting eyes and equalizing sheaves have been inspected prior to lifting and are not damaged or worn. All lifting slings should be tagged in compliance with the relevant Australian Standard and proof testing within the previous 12 months is recommended, and
- Lifting is not performed in windy conditions. This will be at the discretion of the crane operator. However, it is recommended that the lifting of concrete elements should not continue under any circumstances when the wind speed exceeds 45 km/hr (12.5 m/s). In practice, wind speed lower than this figure can be unsafe depending on the surface area of the pre-cast element.

An effective back-up lifting system should be able to:

- withstand the additional impact loading as it takes up any slack in between the primary and secondary lifting systems, and
- effectively contain the load in the event of the failure of the primary lifting system (i.e. prevent any part of the load falling to the ground).

One example of a back-up system for lifting pre-cast floor planks is illustrated in Diagram 8.

It should be noted that although lifting of pre-cast panels over workers is permitted in limited situations, it is not a preferable method, and other erection methods should be investigated prior to its acceptance.

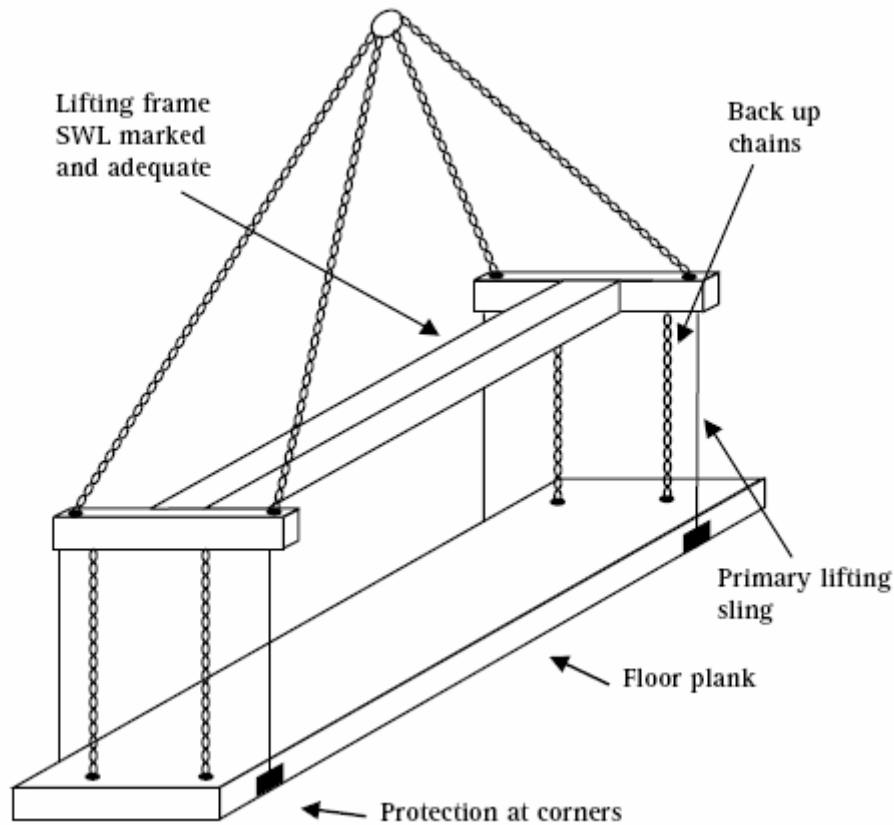

Diagram 8 – One example of a back-up lifting system for a pre-cast floor plank.

14. Panel lifting and erection

14.1 General

The actual lifting of the panels is the time when potential for disaster is highest. Due to their large surface area and mass a great deal of care needs to be taken when lifting, moving and securing panels into position. The likelihood for fatalities when a panel falls over is considerable because the ground area covered by a falling panel is very high and the area in which the panel will fall cannot be controlled. Increasing the risk is the fact that the mobile crane will also fall over and other panels that are struck by the crane or falling panel are also likely to collapse. A domino effect can occur and workers often will not have time to get out of the way before they are struck. With these factors in mind it is extremely important that both the panel erection crew and crane operator are highly skilled and experienced in the erection of panels.

Pre-cast panels are generally smaller than tilt-up panels because they are transported from the pre-cast yard to site by road transport, whereas tilt-up panels are cast on site. The availability of large capacity cranes has meant that larger panels of around 30 tonne are sometimes specified in tilt-up construction. The disadvantage with larger panels is that they are more difficult to handle and greater care needs to be taken to ensure the panels do not strike braces or other panels when they are being moved.

Irrespective of the type of panels being lifted the following should also be ensured:

- Prior to lifting, the panel mass is to be clearly marked on the panel (this can be found on the panel drawing).
- Panels are suspended with the face as near to vertical as practicable, so that the panel is not too difficult to place in its final position as part of a wall (usually 5-15 degrees off vertical).
- Braces - whenever possible should be attached to the concrete panel prior to lifting (reduces need for persons to work at height and minimises the time the panel is supported by the crane).
- The bottom edges of panels to be horizontal such that a bottom corner is not noticeably lower than the other corner.
- No persons are located underneath the panel while it is being lifted and moved (except in the case of pre-cast elements in limited situations - see section 13.2 “Lifting pre-cast elements over workers”).
- Lifting clutch release lines are fitted so that the clutches can be disengaged without the need for workers to climb on top of the panel (see Diagram 9).
- Dowel pins are fitted into the bottom edge of the panels or into the footings prior to lowering. Dowel pins help to correctly locate the panel and also assist the panel to effectively resist wind loads.
- Crane support to be maintained until all braces have been installed and effectively secured to the panel and footings (i.e. hoist rope and lifting slings not to become slack until this is achieved), and
- Levelling shims should not exceed 40 mm height (this will assist in maintaining panel stability).



Diagram 9 – Lifting clutch release lines

14.2 Lifting of tilt-up panels

Tilt-up panels are cast on a casting bed and face lifting inserts are generally used to lift the panels off the bed. The number of face lifters will depend on the capacity of the lifters and the size of the panel but usually ranges between 4 and 8 lifters. It should be noted that it is sometimes difficult to insert the lifters in the exact position specified on the panel drawing due to reinforcement steel being in the way. A slight variation from the drawing on this issue should not be critical providing the insert is inserted in accordance with the manufacturer's specification (e.g. tied to or in close proximity to reinforcement) and the panel is suspended such that the bottom edge of the panel is basically horizontal. The following should also be ensured when the panel is being lifted:

- When lifting a panel off the bed, the force required to overcome panel suction should not be excessive. If the panel does not come free when the crane indicator registers the combined weight of the panel, rigging and other suspended dead load (e.g. strongbacks), lifting should be stopped. Any wedging or jacking of the panel to assist release should be approved by the engineer.
- Lifting clutches to be fully engaged prior to lifting occurring. and
- Lifting gear and sheaves shall be operable and in good condition, and not to become tangled as the crane hook is hoisted up.

Each tilt-up panel should be lifted so that, while suspended, it leans away from the crane. The term 'suicide lifting' is sometimes used in industry to describe the situation when the panel tilts towards the crane. If part of the lifting system fails, in this situation, the panel will fall against the crane and generally cause the crane to overturn. Due to the high risk of injury in these situations, suicide lifting should be avoided.

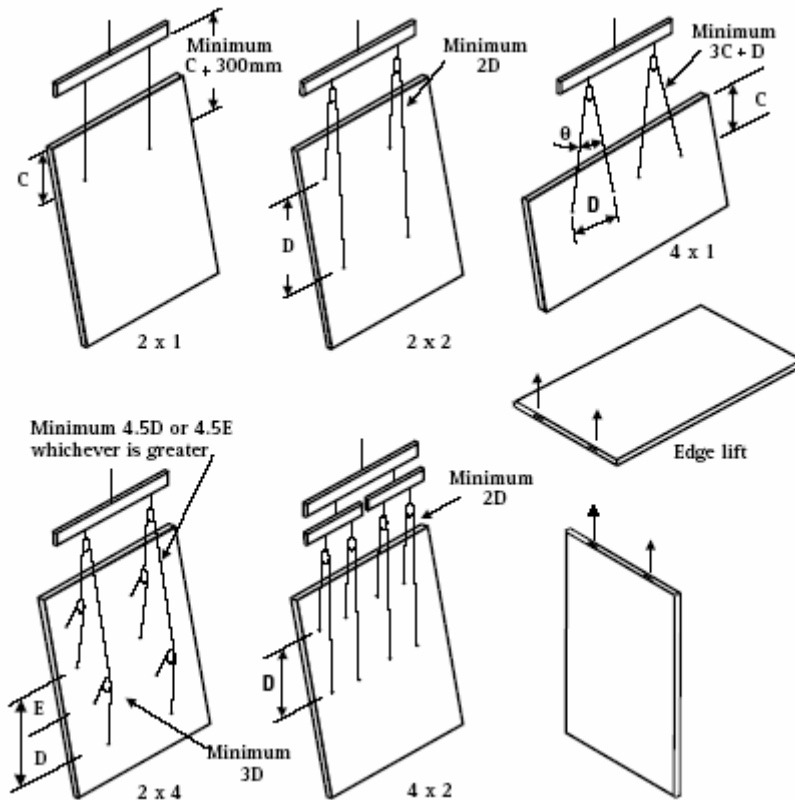

Diagram 10 – Common rigging configurations

Notes:

- 1) Dimensions on slings are total length through pulley
- 2) The lifting insert supplier may specify a maximum value for this angle

14.3 Rotation of pre-cast panels

Where positioned on an A-frame, edge lifting inserts will be cast into the panels, usually two lifters cast into the top edge and two or four in the side edge. The panel is lifted off the truck using the inserts on the side edge. In order to move the panel into its vertical position, the panel needs to be rotated through an arc of 90 degrees, and this can be achieved using one or two cranes. This procedure requires a great deal of skill on the part of the crane driver(s). Even though the panel will be suspended by two hoist ropes, more than 50 percent of the panel weight will be applied to one of the hoist ropes due to the cantilever (see Diagram 12).



Diagram 11 – Rotation of a pre-cast panel

An engineer can be approached to provide guidance on the minimum required capacity of the crane(s) used for rotating panels. However, the rule below in general use by industry may be used where such advice is not provided as long as the conditions are complied with.

Rule: Where one crane is used the capacity of the auxiliary winch should have a minimum capacity of 75 percent of the panel mass. Where two cranes are used the crane handling the lesser load should also have a minimum capacity of at least 75 percent of the panel mass. Conditions to be complied with:

- The distance from the auxiliary winch rope lifting point to the end of the panel is not to exceed 1/4 of the panel length.
- The included angle between the main hoist rope and auxiliary hoist rope is not to exceed 45 degrees.
- Panels are to be rotated such that the panel is suspended in its rotated position by the main winch (if one crane used), or the larger capacity crane (if two cranes used).
- The combined weight of the auxiliary hook block and lifting gear is not to exceed 200 kg.
- Where one crane is used the main winch and auxiliary winch drives should be independent (i.e. have separate clutches).
- There are to be no cut outs in the half of the panel closest to the main winch rope panel lifting point.
- The panel is to be adequately reinforced to withstand the lifting stresses.

If the conditions above cannot be complied with an engineer should verify the minimum required capacity of the hoist ropes.

'Rooster sheaves' is the name given to the short boom extension and sheave set-up attached to the boom head of the crane when panels are rotated. Rooster sheaves and the associated rigging on the boom head should be designed and certified by an engineer.

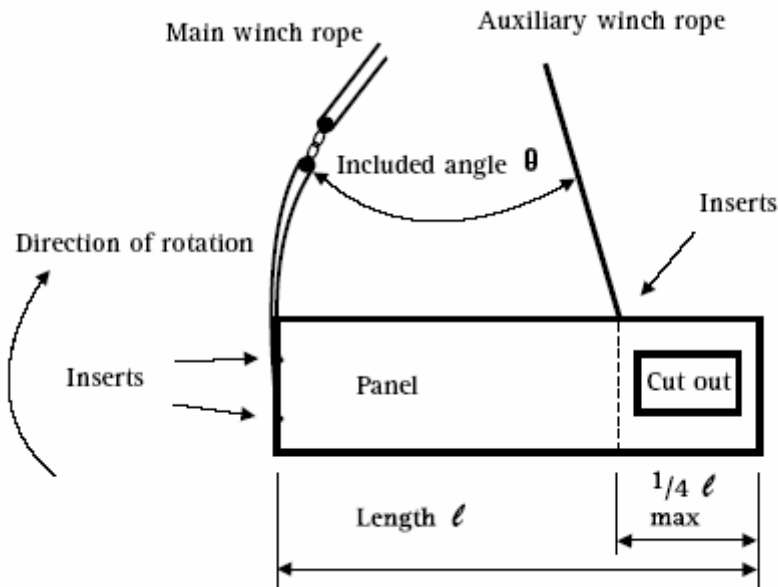

Diagram 12 – Initial position of panel prior to rotation

15. Operation of plant near braces and panels

The use of mobile plant close to panel braces can be extremely hazardous due to the risk of the braces being struck and panels collapsing. Braces are designed to resist wind loads applied to panels and not to resist impact loadings with moving plant or their moving parts. When a collision with a brace occurs, and the brace is bent, the panel will be pulled towards the side on which the braces are located. The braces are then exposed to part of the dead-weight of the panel and are not designed to resist such high loadings. The situation is made worse by the fact that the brace has been 'kinked' and will have a much lower compressive strength than in its undamaged condition.

Braces that are struck by mobile plant are likely to collapse in a very rapid and uncontrolled fashion and there can be a very high risk of fatalities occurring both to persons operating the plant and to other persons located in the area. A falling panel is also likely to strike other panels and a 'domino' effect can occur.

This hazard can apply to all types of plant including backhoes, mobile cranes, excavators and elevating work platforms (EWPs). In particular, it can apply when a crane is being used to erect the structural steelwork that will tie the panels together. In

this situation controls must be implemented to prevent parts of the crane **and** the suspended load from contacting the braces and panels.

The use of a spotter to assist with preventing contact may not be an effective control measure, when used alone, due to noise on site, delay in the plant operator acting on the spotter's signals and incorrect interpretation of the spotter's signals.

Mobile plant should generally not be operated or travel close to, erected panels and braces unless there is a very good reason for the plant being there (i.e. the use of a boom lift EWP to assist in the installation or removal of braces).

Where plant is operated in close proximity to braces and panels, control measures should be implemented to prevent any part of the plant contacting a brace or panel. Under no circumstances should mobile plant actually be permitted to make contact with an installed brace. Some control measures that may be used to reduce the risk of mobile plant contacting braces or panels include:

- The use of a spotter to signal the plant operator to stop the plant in the event of any part of the plant approaching a brace or panel. Such a system would have to ensure that the communication method between the spotter and operator was effective and took into account factors such as noise on site and the spotter possibly being out of view of the operator.
- Use of hazard tape, 'para-webbing' and/or signage to make the brace position obvious, particularly where access areas are located, and
- The use of plant that reduces the risk of contact with panels or braces. Two examples are:
 - the use of mobile cranes that do not have to be located where slewing contact with a brace is possible, and
 - the use of boom type EWPs instead of scissor lifts (note: this may not always improve the situation).

Mobile plant travelling from one area on site to another should not travel close to braces if it is possible to travel by an alternative route. It would be extremely unlikely that there would be a legitimate reason for mobile plant to be driven underneath an installed brace.

16. Working at height

In tilt-up and pre-cast construction, persons are required to work at height to perform the following activities:

- attaching the panels to one another or to structural steelwork prior to removal of the braces
- attachment and removal of braces to and from panels
- application of caulking to the vertical joints between panels, and
- patching work.

Most work at height on tilt-up construction should either be performed from platforms with edge protection - including the use of EWPs or mobile scaffolding. Ladders

should not be used unless the height is not excessive and the work is of short duration and of a light duty nature. The removal of braces from panels using ladders could be unacceptable for the following two reasons:

- The possible need for the person on the ladder to support the end of the brace after it is unbolted and lowered to the ground. The person would have to step down the ladder with the end of the brace in one hand. This is not “permitted work” under Part 20 of the *Workplace Health and Safety Regulation 2008*.
- The height of the ladder would be excessive for larger panels creating significant risks for working from a ladder (i.e. the ladder would flex and be more difficult to secure).

In some situations, the panel erector may be able to justify the use of ladders to remove braces by ensuring that the person on the ladder only undoes the bolt securing the brace and the brace is slowly lowered by workers on the ground who ensure the foot remains in contact with the vertical panel as the brace is lowered. This procedure would only be acceptable where the weight of the brace is not excessive and the brace can be lowered in a controlled manner.

16.1 Elevating work platforms (EWPs)

On tilt-up jobs boom lift type EWPs are usually preferable to scissor lifts because they have superior reach to access more awkward areas and do not have to be driven right next to an erected panel in order to get access. There are also more ‘rough terrain’ type boom lifts available, than there are with scissor lifts, and these can be driven over poor ground conditions.

All EWPs used on site should comply with *AS 1418.10 Cranes (including hoists and winches) - Elevating work platforms*. This standard requires that EWPs be stability tested on a 5 degree gradient. Many EWPs operating in the industry are either fitted with an audible warning device or a motor cut-out that operates when the unit is driven on a side gradient exceeding 5 degrees.

The following should be noted in relation to EWPs:

- The EWP should be fitted with a manufacturer’s identification plate that includes:
 - unit make, model number and serial number, and
 - a statement that the unit complies with *AS 1418.10*.
- Persons in boom type EWPs are to wear full body fall arrest harnesses complying with *AS/NZS 1891.1 Industrial fall-arrest systems and devices – Harnesses and ancillary equipment*. The lanyard should include a personal energy absorber and be attached to a fall arrest anchor in the basket rated at 15 kN.
- There should be evidence that the EWP has been maintained so as to be safe.
- The basket or platform on the EWP has its maximum capacity or safe working load clearly marked and is not being overloaded.
- EWPs are only to be operated in accordance with the manufacturer’s specifications. Some units may only be driven around the site with the boom lowered so that it is just above ground level.

Further guidance on the safe use of elevating work platforms is included in AS 2550.10 *Cranes, hoists and winches - Safe use – Mobile elevating work platforms*.

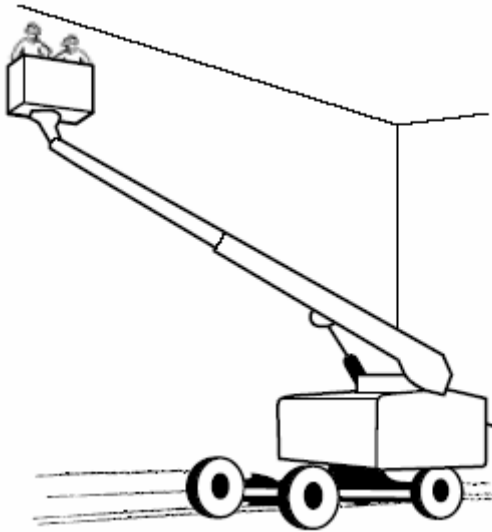

Diagram 13 – Boom type EWP.

16.2 Scaffolding

Scaffolding should have edge protection in accordance with Part 20 of the *Workplace Health and Safety Regulation 2008*. Guidance is also provided in the *Scaffolding Code of Practice*. Some of the issues relating to the scaffolding itself are:

- Free standing height of scaffolding to the work platform should be no higher than three times the least base width.
- Access on mobile scaffolding to be provided internally (i.e. with a trapdoor).
- Standards to be provided with base plates or sole boards to distribute point loading.
- Damaged tube and components not to be used - this is particularly important with aluminium scaffolding using thin walled, high tensile strength tube because dents in the tube can have a major effect on its strength.
- Scaffolding where a person or object could fall 4 metres or more to be erected by a licensed scaffolder.

16.3 Ladders

Part 20 of the *Workplace Health and Safety Regulation 2008* specifies a number of requirements for the use of ladders. These requirements include:

- Ladders not to be used for work other than “permitted work”, which is work where:
 - the material or equipment being carried does not restrict movement or cause the loss of balance, for example, power tools that are easily operated one-handed
 - the trunk of the body remains centred on the ladder – tasks should not require overreaching

- equipment can be used with one hand (unless a control to prevent a fall is used).
- Single ladders not to exceed 6.1 metres. Extension ladders not to exceed 7.5 metres.
- Ladders to be industrial ladders with a load rating of at least 120 kg.
- Ladders to be secured against movement.
- Single and extension ladders to be placed at an angle of between 70 degrees and 80 degrees to the horizontal.

In addition to the regulatory requirements, issues regarding the safe use of ladders should be considered when undertaking risk management as required by the Regulation. Some of these issues include:

- A person's feet should not be higher than 900 mm to the top of the ladder. In the case of step ladders, a person's feet should be no higher than the third tread from the top plate.
- Step ladders should only be used in the fully opened position with the locking spreader engaged. Chain or rope spreaders should not be used.
- Ladders should be set up on a firm, level surface and not used on scaffolding or EWPs to gain extra height.
- Ladders should not be used in access ways, to avoid persons being located under the ladder and to avoid plant colliding with the ladder.
- Ladders should not be handled or used where it is possible for the ladder or user to contact electrical power lines. Metal or metal reinforced ladders should not be used in the vicinity of live electrical equipment (timber ladders often have metal running along their length).

17. Proximity to overhead powerlines

Contact with overhead powerlines can pose a major risk on tilt-up sites due to the height of the panels, the use of mobile cranes and other plant and because workers are required to work at a height where contact with power lines may be more likely.

The *Electrical Safety Regulation 2002* regulates work around overhead power lines. Practical advice on such work is also provided in the *Code of practice - Working Near Exposed Live Parts*. One of the requirements is that workers and plant should maintain an "exclusion zone" of 3 metres around live overhead power lines. Greater "exclusion zones" apply to high voltage lines (6 and 8 metres depending on the voltage). (In certain limited situations there may be exceptions to this - for details see the *Electrical Safety Regulation 2002* and the *Code of practice - Working Near Exposed Live Parts*.)

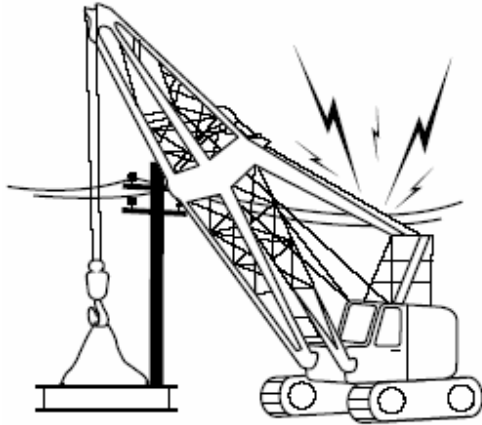

When operating plant near power lines a number of factors must be considered when implementing systems to maintain the “exclusion zone” from overhead power lines. These include the following:

- Identify the minimum clearance distance from the closest part of the crane or suspended load to the power line.
- Allowances for sway and sag of the overhead lines should be made. Sway is usually caused by wind and sag occurs when the temperature of the line fluctuates.
- Persons operating plant and vehicles must stay outside the “exclusion zone” at all times, and
- The *Code of Practice – Working Near Exposed Live Parts* requires a “safety observer” when the crane or plant could enter into the “exclusion zone”.

The exclusion zones for Queensland Rail power lines and those of some power authorities may differ. It is the responsibility of the crane owner and builder to check with the person in control of the overhead electric line.

There are a number of devices available that either assist in preventing contact with power lines, or reduce the degree of risk in the event of contact. Such devices include the following:

- The use of ‘tiger tails’ on power lines act as a visual aid that assists in preventing contact by highlighting the location of the power line. Only low voltage lines (under 1000 volts) can be continuously covered with tiger tails, which leaves the higher lines on power poles (usually at least 11 000 volts) exposed. Note: tiger tails are not designed to insulate the wires and therefore the “exclusion zone” must be maintained.
- Limiting devices to prevent the crane jib or load from entering the exclusion zone or warning the operator before the jib enters the “exclusion zone”. These devices are generally more suitable for tower cranes rather than mobile cranes. If a limiting device is used, the system should be designed to “fail safe” or should at least meet category 4 reliability in accordance with *AS 4024.1 Safety of machinery - General principles* or European Standard *EN 954-1 Safety of machinery – Safety related parts of control systems*.

- Electronic proximity devices that audibly warn the crane operator when the minimum clearance distance is being approached.

Irrespective of whether safety devices are being used, the “exclusion zone” must not to be encroached.

Further information may be obtained in the *Electrical Safety Regulation 2002* and the *Code of Practice - Working Near Exposed Live Parts* or on the *Electrical Safety Office* website www.eso.qld.gov.au.

18. Licensing issues

The panel erection crew must be holders of intermediate rigging (RI) or advanced rigging (RA) licence classes or be trainees. Trainees must be supervised and logbooks showing previous training must be kept.

Crane operators and persons performing dogging duties must hold appropriate licences. Occupational licences issued under previous legislation, and by other State authorities, may be used provided the competencies required by the particular operation are within the scope of that licence.

The relevant licence classes for mobile crane operators, other than vehicle loading cranes, are as follows:

- CN Non-slewing mobile crane with a capacity of more than 3 tonne.
- C2 Slewing mobile crane with a capacity of 20 tonne or less.
- C6 Slewing mobile crane with a capacity of 60 tonne or less.
- C1 Slewing mobile crane with a capacity of 100 tonne or less.
- C0 Slewing mobile crane with a capacity of more than 100 tonnes.

Any person with a dogger licence class or a rigger licence class is permitted to perform dogging duties.

Any person operating a boom type EWP with a boom length of 11 metres or more must hold a WP type licence class.

Persons erecting scaffolding where a person or object could fall 4 metres or greater must hold at least a Basic Scaffolding SB licence class or be trainees.

A qualification register for persons involved in panel erection is included in Appendix D.

Appendix A - Sample of engineer's certification letters

6 September 2002

Hector Smith
Hector Panel Erections Pty Ltd
21 Concrete Drive
Urbanville QLD

Dear Mr Smith

Pineapple Waters Project – Spiky Road, Golden Beach

I certify that the concrete panels detailed below, have been designed in accordance with Australian Standards *AS 3850 - Tilt-up concrete construction* and *AS 3600 - Concrete structures*, for both in-situ loads and erection loads.

| Panel number | Drawing number |
|---------------------|-----------------------|
| P-1 | 302 – 1 Rev 1 |
| P-2 | 302 – 2 Rev 2 |
| | |
| | |
| | |

The lifting inserts have a minimum factor of safety of 2.5 provided the inserts are used in accordance with the manufacturer's specifications and the concrete has reached a minimum strength of _____ MPa (as recommended by the insert manufacturer).

The panels will be suitable for lifting when the concrete strength has reached ____ MPa.

Yours faithfully

Signature
Engineer's name
RPEQ No.

Sample letter for lifting and in-situ loads.

6 September 2002

Hector Smith
Hector Panel Erections Pty Ltd
21 Concrete Drive
Urbanville QLD

Dear Mr Smith

Pineapple Waters Project – Spiky Road, Golden Beach

I certify that the temporary bracing layout as detailed in the drawings listed below has been checked for wind loading and complies with Australian Standards *AS 3850 Tilt-up concrete construction* and *AS 1170.2 Structural design actions – Wind actions*.

| Drawing description | Drawing number |
|--|-----------------------|
| Site plan showing panel locations | SP - 107 |
| Brace configurations (i.e. showing brace types, angles, extensions, etc) | BC – 1 to 23 |
| Deadmen | DM – 1, DM 2, DM 3. |

I have checked the capacity of braces, deadmen anchor blocks (or slab design), panel inserts and anchors used between the brace foot and deadmen.

I have selected the following parameters from *AS 1170.2* in determining the adequacy of the temporary bracing system:

Region: _____

Terrain category: _____

Return period: _____

Yours faithfully

Signature
Engineer's name
RPEQ No.

Sample letter for temporary bracing and wind loading

Appendix C - Panel lifting and temporary bracing checklist

Job address: _____ Panel manuf. and ABN: _____

PC and ABN: _____ Panel erector and ABN: _____

Panel lifting

Crane

| Item | Result | Initials | Comment |
|---|--------|----------|---------|
| Crane has adequate capacity (if tilt-up, add lean distance to radius) | | | |
| Lift plan completed – includes site plan and lifting locations | | | |
| Ground condition and slope (no more than 1 degree for ‘pick and carry’ cranes – cranes on outriggers adequate packing under pads – no penetrations or covered pits in area) | | | |
| Crane safety features operational (load indicator, anti two block, boom angle indicator, hook safety catch) | | | |
| Crane maintenance log book complete and up to date | | | |

Lifting gear

| Item | Result | Initials | Comment |
|--|--------|----------|---------|
| Lifting clutches compatible with inserts | | | |
| Lifting clutches and inserts marked with manufacturer’s ID | | | |
| Lifting gear sheaves operational | | | |
| Lifting slings suitably marked with ID | | | |
| Lifting gear test/inspection results available | | | |
| Remote release lines fitted | | | |

Other items

| Item | Result | Initials | Comment |
|--|--------|----------|---------|
| Panel checklist completed (panels okay for lifting) | | | |
| Certification – crane operator, panel erectors (intermediate rigger to be present and supervising panel placement) | | | |
| Bond breaker functioning | | | |
| Workers not in potential crush zone (from crane or falling panels) | | | |
| Workers wearing high visibility clothing | | | |
| Exclusion zone for members of public and other buildings set up | | | |
| Power lines – adequate clearance – check legislation | | | |

Temporary bracing

Certifying engineer: _____ ABN: _____

Deadmen or floor slab

| Item | Result | Initials | Comment |
|--|--------|----------|---------|
| Drawing showing layout of panels and temporary bracing prepared | | | |
| Deadmen / slab has been constructed in accordance with engineer's specifications | | | |
| Deadmen / slab concrete has reached strength specified by engineer | | | |
| Cast in anchors are as specified by engineer (size, type and depth) | | | |

Braces

| Item | Result | Initials | Comment |
|--|--------|----------|---------|
| Braces as specified by engineer or with capacity exceeding minimum specified by engineer | | | |
| Brace condition | | | |
| Marked with identification plate | | | |
| Correct number of braces used | | | |
| Braces installed in accordance with engineer's specifications | | | |
| Brace locking pins fitted with retaining device | | | |
| Where access by members of public likely retaining device has key to unlock | | | |
| Anchor head and washer size suitable for brace slot size (i.e. large enough) | | | |
| Suitable access for workers at height | | | |

Checklist completed by (name and signature): _____

Drill-in type anchors

| Item | Result | Initials | Comment |
|---|--------|----------|---------|
| Anchor type suitable (drop-in, low-load slip and self-drilling anchors not permitted) | | | |
| Anchors as specified by engineer or with capacity exceeding minimum specified by engineer | | | |
| Documentation starting setting torque available | | | |
| Verification that correct torque has been applied (i.e. torque wrench readings) | | | |
| Chemical anchors – documentation verifying every anchor proof loaded | | | |

Checklist completed by (name and signature): _____

Appendix D - Qualification register for panel erection

Project name and address: _____

Licensing register (Licence holders)

| Name | Licence class | Licence number | Activity involved in* |
|-------------|----------------------|-----------------------|------------------------------|
| | | | |
| | | | |
| | | | |
| | | | |
| | | | |

*i.e. crane operation, supervision, panel securing, etc.

Trainee register

| Trainee name | Activity involved in | Trainee logbook supplied | Supervisor | Period of experience in activity |
|---------------------|-----------------------------|---------------------------------|-------------------|---|
| | | | | |
| | | | | |
| | | | | |
| | | | | |